

# FORKS SCALE SYSTEM

## PLUG&PLAY RETROFIT SOLUTION FOR FORKLIFTS



### WEIGH THE GOODS AS YOU MOVE THEM

These sturdy, reliable and easy to install forks are designed to optimize the everyday weighing activities. They can be mounted on any type of forklift in place of the original forks and allow to weigh the products during their transport and lifting, up to 2500 kg. There is no need to use other tools, now you can reduce work times, speed up processes and save on costs.

A state-of-the-art technology that turns an ordinary truck into a mobile electric scale guaranteeing high-level performance.



### PLUG & PLAY INSTALLATION

The installation is very easy, forks can be mounted in just few and easy steps, without cables or wires. The great advantage is the flexibility as they may be easily removed and reinstalled in another truck. Once mounted, they transmit the data, through Bluetooth connection, to the wireless display enabling the operator to check the weight of the loads. Accelerometer for automatic switch-on of the moving forks provided as standard.



### ADVANCED PRECISION

The system can quickly weigh goods with very high precision. The weight acquisition load cell technology, made in stainless steel with IP68 protection, combined to the last generation software, guarantee high accuracy of 0.1%.

The compact backlit display for viewing the weight in the cabin does not take up much space and leaves great visibility for the operator.

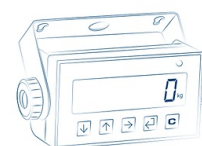

## BATTERY

Each fork is powered by rechargeable plug&play lithium battery with 90-hour autonomy making the system always ready to weigh when needed.

Battery charger is included in the equipment.

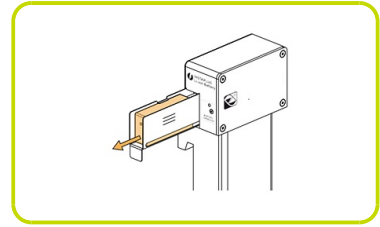

## SAFETY

Thanks to this intelligent weighing system it is no longer necessary to take the load and get in and off the machine every time to weigh it. Among other features, the display sends an instability error message that indicates if the load is not in the correct position. It alerts as well the operator to overloads and helps to monitor the weight loaded, thus avoiding dangerous movements and overturning.



## OPTIONAL

### CE-M APPROVAL

Approved version of forks essential for selling by weight in legal for trade applications. They offer higher accuracy in order to simplify processes, save time and improve quality (for example for control of prepackaged goods).



### PRINTER

It is possible to equip the system with a thermal printer to be able to quickly trace on the spot all weighings made.



## Waage

Tragkraft	Bis zu	2500 kg
Ziffern	Q.ty	6
Kilogramm		Ja
Pfund		Ja
Leergewicht		Ja
Bewegliche Ladung		Ja
Summierung		Ja
Zählung		Ja
Genauigkeit	%	0,1
Shear-beam Lastzellen	Q.ty	4
Abteilung (1000-2000 kg)	kg	2
Unterteilung (0-1000 kg)	kg	1

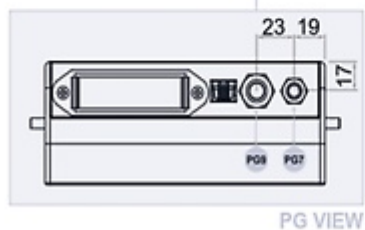
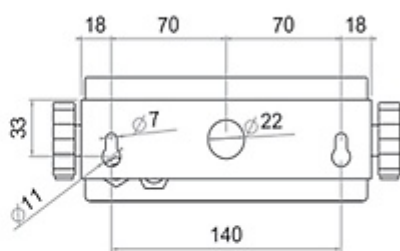
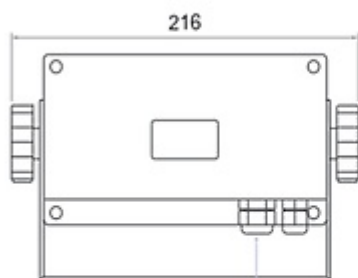
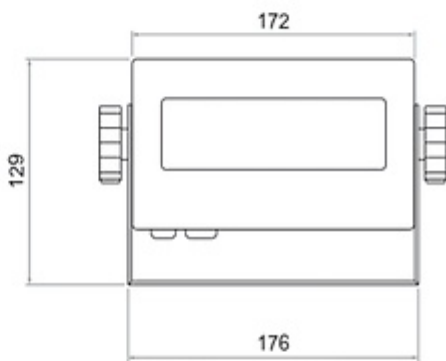
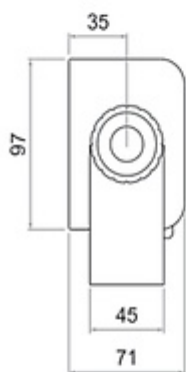
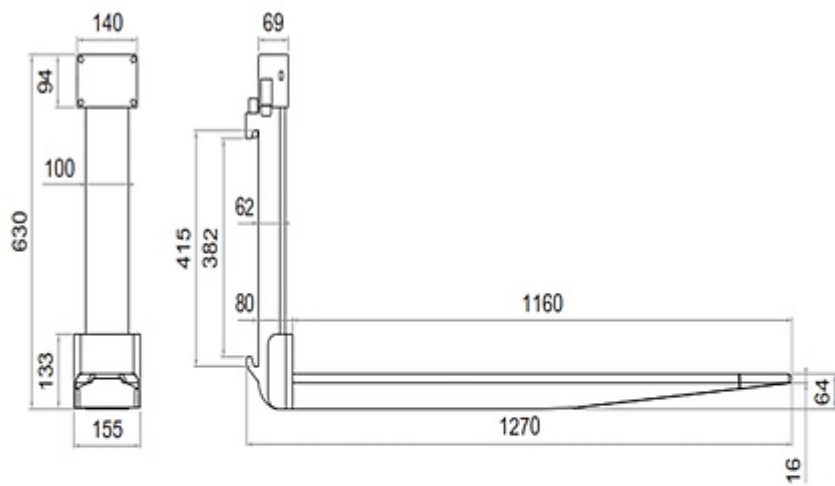

The information is aligned with the Data file at the time of download. Printed on 24/10/2023 (ID 15468)

©2023 | PR Industrial S.r.l unipersonale – Loc. Il Piano – 53031 Casole d'Elsa (SI) – ITALY. Company subject to the management and coordination of Generac Power Systems Inc. | All rights reserved | Image shown may not reflect actual package. Specifications subject to change without notice

